



Fire Marshal's
Information Packet for
Residential and Detached Accessory Buildings

Fire Flow Requirements

Note: Fire-flow calculation area shall be the total square footage of all areas within exterior walls, including only areas that are fully enclosed on all sides and which have a full ceiling height (6'-8" or greater). Area measured to the outside edge of enclosure walls. Breezeways connecting buildings will be included in the area measurement.

Grade per Whatcom County Development Standards (WCDS), Chapter 5, Road Standards. Residential and residential accessory structures accessed by roads or driveways exceeding 12% grade require mitigation such as an automatic sprinkler system, per NFPA 13-D, throughout the applicable building(s); an approved fire flow system; equivalent mitigation approved at the discretion of the Fire Marshal in addition to standard access road requirements.

If a **remodel** is proposed, calculation of existing building area is required on application/plans for a fire area calculation.

Calculated fire-flow area is **greater than 4,000 square feet. Greater than 2500 square feet for detached accessory building.**

One of the following options is required:

- A fire hydrant connected to a municipal or water association system within 600 feet (driving route) of the proposed building which produces a minimum 500 GPM at 20 psi for a minimum duration of one hour. ***Availability Notification for Public Fire Water form required.**
- An approved NFPA 13-D residential fire sprinkler system will be installed prior to occupancy. ***Separate Fire Marshal's Permit is required.**
- A fire flow system consisting of a tank or pond, approved fire pump, and a fire hydrant within 600 feet (driving route) of the proposed building. The system must produce 500 GPM at 20 psi for minimum duration of one hour. ***Separate Fire Marshal's Permit is required.**
- A NFPA 13-D automatic sprinkler system is required throughout all dwellings with a measured fire area exceeding 8,000 square feet. In addition, fire-flow for dwellings with a fire-flow calculation area exceeding 8,000 square feet (743.2 m²), shall not be less than that specified in Table B105.1, as amended by Whatcom County, except that the flow duration may be a minimum of one hour.

Driveway and/or Private Road Requirements

Note: all driveways must have an overhead clearance of 13'6" for entire required width of the driveway.

- Private access bridges include all applicable information from the Private Bridge Permit Review Checklist and complete engineer's assessment submitted with application.
- Requirements per the "Private Roadway or Driveway Matrix" are shown on an appropriately scaled site plan.
- Scaled site plan clearly shows **entire length of driveway from Whatcom County mainlined road**, up to the proposed structure.
- Driveway is 150' or greater in length:
 - Fire apparatus turn-around feature required on scaled site plan.
Note: Must be no closer than 50' and no further than 150' from structures.
(see example handout)
 - *Address post required to mark long driveways.
- Driveway is 600' or greater in length:
 - Fire apparatus turn-out feature(s) required on scaled site plan.
Multiple turn-outs may be required, depending on length of driveway.
(see example handout)
- Portions of the driveway or private road are 12% or greater in grade.
 - Residential fire sprinkler system, meeting NFPA 13D, will be installed due to steep driveway. (Separate Fire Marshal's Office permit is required.)
 - Security gate locations are shown on scaled site plan, if proposed.
(Separate Fire Marshal's Office permit is required for all security gates and other emergency access restrictions)

Engineering Standards for Private Roadways and Driveways

This section applies to roads that are privately owned, generally within an easement providing direct access to private land(s) for local traffic movement and connect to local public access, collector or arterial roads. Private roads are maintained with private funds and where the county, municipality or WSDOT performs no maintenance.

1. Criteria for Authorization: All new roads shall be public; however, private roads may be permitted when so provided in appropriate ordinances or at the discretion of the County Engineer when:
 - a) Covenants have been approved and recorded with the County which provide for maintenance of the private roadways and associated parking areas by the owners in the development, including placing of liens for non-payment of fees, and/or road maintenance agreement(s) on the face of the Long Plat, Short Plat or Binding Site Plan.
 - b) Provision is made for the roadways to be open at all times for emergency and public service vehicle use.
 - c) The private road is not needed as a public road and will not obstruct public street circulation.
 - d) Intersection spacing between private roads shall be consistent with the spacing shown in Section 505.M.
 - e) The roads are within a private community with a corporate identity, Homeowners Association, Common Interest Community, or similar, as identified by the State of Washington.

2. Private Roadway or Driveway Design (Residential Use Only)
 - a) Geometrics: (See 505 Road Types and Geometrics, Table 1 & 2 for other road geometric requirements).

Private Roadway or Driveway Matrix								
Designation	Setting	Incremental Grade, %	Minimum Surface Treatment	Minimum Roadway Width (ft)	Unobstructed Minimum Vertical Clearance, ft	Minimum Turning Radii (ft)		See also Standard Drawing(s)
						Inside	Outside	
Driveway	Rural & Urban	<12	CSTC ⁽²⁾	12	13.5	25	40	505.E-6
		12 to <15	Paved ⁽³⁾					
		15 – 18	Grooved PCC ⁽⁴⁾					
Private Roadway	Rural	<12	CSTC ⁽²⁾	20 ⁽⁵⁾	13.5	25 ⁽⁶⁾	45 ⁽⁶⁾	505.E-1
		12 to <15	Paved ⁽³⁾					
		15 – 18	Grooved PCC ⁽⁴⁾					
	Urban	<12	Paved ⁽³⁾	20 ⁽⁵⁾				505.E-2
		12 to <15	Paved ⁽³⁾					
		15 – 18	Grooved PCC ⁽⁴⁾					

- (1) Driveway serves up to 20 ADT (or two dwelling units)
- (2) Crushed surfacing top course
- (3) Either Portland Cement Concrete (PCC) or Hot Mix Asphalt (HMA)
- (4) Portland Cement Concrete
- (5) See Standard Drawing(s) for when additional width is required
- (6) See also 505.I.3-Horizontal Curves

b) Additional County fire code requirement for "Fire Apparatus Access Roads" are contained in WCC 15.04.010 and as amended in WCC 15.04.040 and include:

- Turnouts-For driveways and roadways less than 20 feet wide, see Standard Drawing 505.E.5.
- Turnarounds - Establish turnarounds for driveways and roadways greater than 150 feet in length per Standard Drawing 505.E-6, 505.L-1, or 505.L-2 as applicable (Subject to other related codes and standards, i.e. Title 20.80).
- Fire Hydrants - Where a fire hydrant is located on a Fire Apparatus Access road, the minimum roadway width shall be 26 ft. for length of 40 ft. centered on the fire hydrant.
- Bridges - At the discretion of the Fire Marshal all bridges shall meet the requirement in Section 513 *Bridges and Associated Retaining Walls*.
- Security Gates and Emergency Accesses - The County Fire Marshal requires a separate permit for any security gate or emergency access restraining device/system.
- Access Approach Surfacing Requirements – All fire apparatus access approaches shall have an approved paved/hard surfaced apron unless otherwise directed pursuant to this Section and Section 508 *Roadside Features*.
- Additional or Alternative Measures – The County Fire Marshal may consider or require additional or alternative fire protection measures on a case by case basis.

RESIDENTIAL TURNAROUND OPTIONS

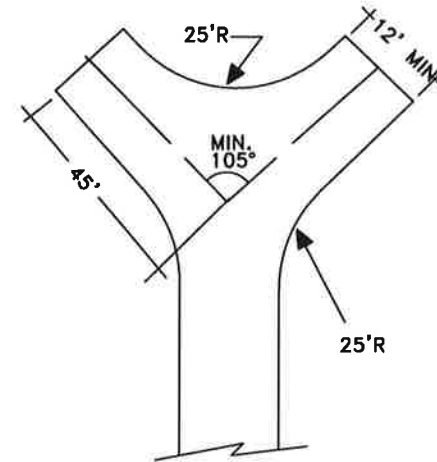
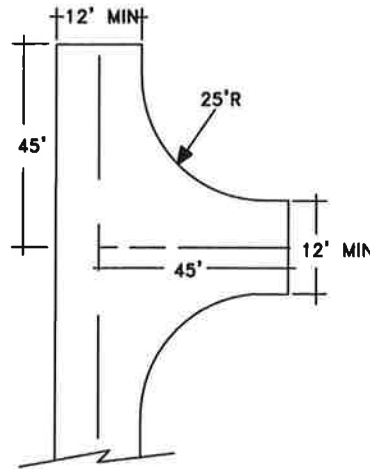
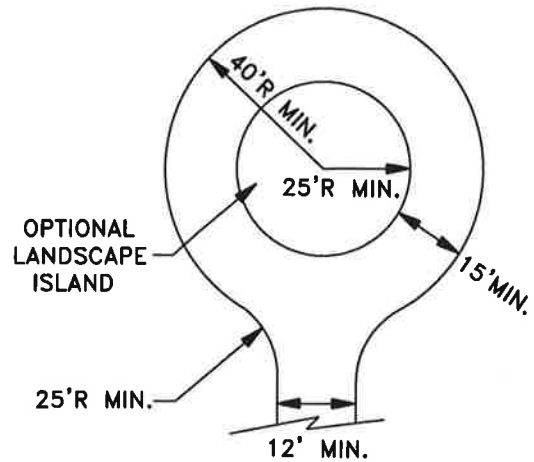

DRIVEWAY SECTION

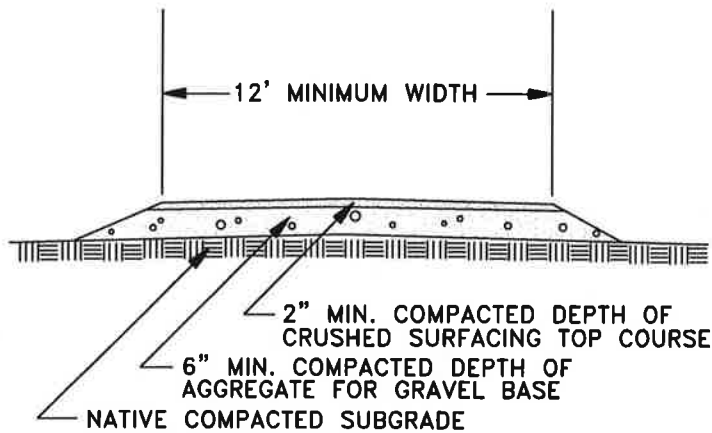

- DRIVEWAY GRADES $\geq 12\%$ SHALL BE PAVED WITH 2 ½ INCHES MIN DEPTH COMPACTED HMA CLASS ½", $\geq 15\%$ SHALL BE GROOVED PORTLAND CEMENT CONCRETE, GRADES SHALL NOT EXCEED 18%.
- RESIDENTIAL TURNAROUND MUST BE A MINIMUM OF 50' FROM STRUCTURE, BUT NOT MORE THAN 150' FROM STRUCTURE.

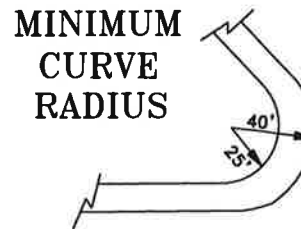

DRAWING 505.E-6
RESIDENTIAL DRIVEWAY DETAILS
WHATCOM COUNTY DEPARTMENT OF PUBLIC WORKS

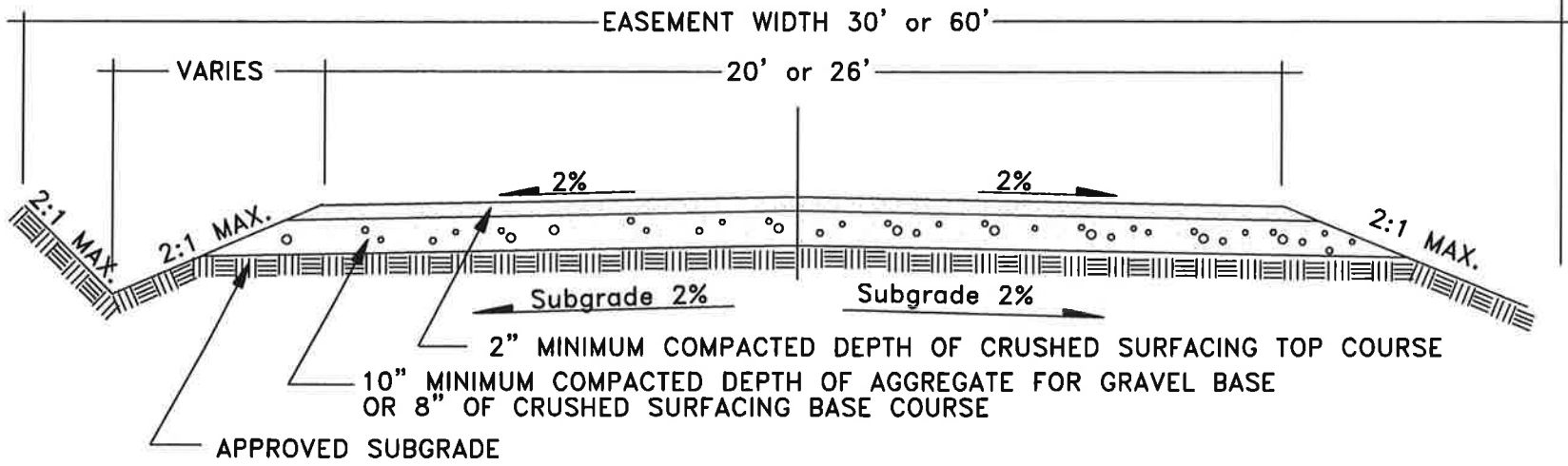

NOTES:

1. All roads shall have a paved approach to intersecting paved roads. See Drawing 505.E-3.
2. Grades $\geq 12\%$ shall be paved with 2 1/2 inches minimum compacted depth class B asphalt pavement.
3. Grades $\geq 15\%$ shall be grooved Portland Cement Concrete. Grades shall not exceed 18%.
4. Engineering design: See Section 507.A.
5. All private roads shall provide a turnaround. Turnaround configurations are shown on Drawing 505.L-2.
6. All testing shall be as per approved plans.

ADT*	Minimum Easement Width Req'd	Overall Roadway Width
≤ 20	30'	12' - See Drawing 505E-6
21 - 60	30'	20'
61-120	60'	26'
>120 - See Public Rural Road Standards, Drawing 505.B-1		

* One single family residential unit equates to 10 ADT.

DRAWING 505.E-1
RURAL PRIVATE ROADS SERVING ACREAGE TRACTS DETAIL
WHATCOM COUNTY DEPARTMENT OF PUBLIC WORKS